

CHAPTER I

PARTICULARS OF ORGANIZATION, FUNCTIONS AND DUTIES

The Primary functions of the State Police are prevention and detection of crime, maintenance of law and order and to bring offenders to justice. The State Police is headed by the Director General of Police. It is organized into different wings/units each headed by a Senior officer as outlined in the chart below :-

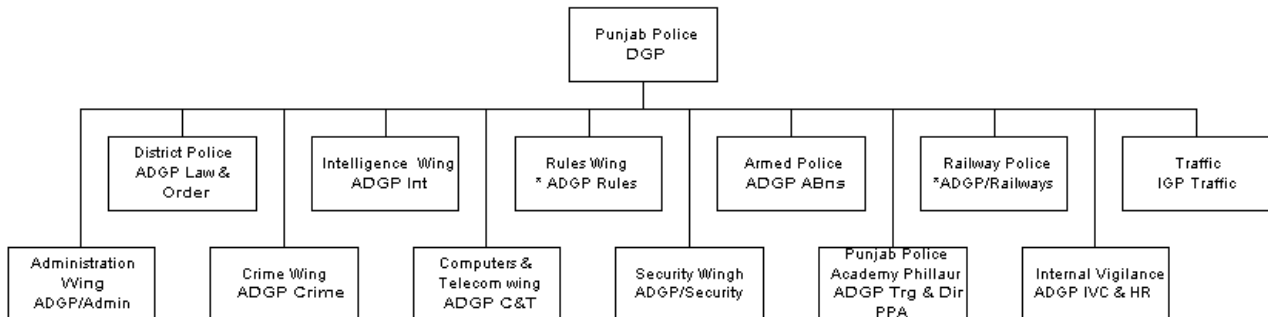

* presently these posts are being occupied by DGP rank officers

A. DISTRICT POLICE SET UP

District Police reports to Director General of Police through Addl. Director General of Police, Law & Order and the main functions of the district police are as under:-

1. **Prevention and detection of crime:** Preventive steps include beat patrolling, setting up of Nakas, gathering of intelligence and management of an effective control room. Detection of crime includes registration of an FIR, investigation, searches, seizures and arrests (if any) followed by submission of final report in the trial court and subsequent follow up during prosecution.
2. **To bring offenders to justice:**

3. **Maintenance of law and order:** This includes security of threatened persons, security arrangements for important events such as festivals/ processions etc and security arrangements for the visits of VVIPs. It also includes tackling of law and order problems and public disruptions such as student unrest, labour problems and dharnas etc. An important aspect of urban policy is traffic regulation and management. During disasters, calamities and major accidents, the police is one of the primary agencies involved in relief and rescue activities.
4. Another major function of the police is the redressal of grievances of the public. This could be resolution of local disputes, family disputes, Redressal of traffic problems etc.

In addition, the district police also provides some citizens oriented services listed below :-

- 1) Verification of applications for passport,
- 2) Police clearance certificates
- 3) Verification for Govt service
- 4) Verification for arms licenses.
- 5) Verification of convicts for parole
- 6) No objection certificate for registration of change in ownership of vehicles
- 7) Verification of tenants/ servants etc
- 8) Verification/ inspection of licenses issued under the Arms Act, Excise Laws, Explosives Act and Petroleum Act.

The district police set up is organized in the form of zones headed by IGsP Zonal and ranges headed by Range DIsG Ranges comprise of districts headed by Senior Supdt. of Police.

The districts are further divided into sub-divisions comprising of police stations. Each police station is supervised by the Station House officer (SHO) who is generally of the rank

of sub inspector and in some cases even of the rank of Inspector of Police. A police station may have one or more police posts (PPs). A sub division comprises of one or more police stations which are supervised by the Dy.Suptd of Police of the sub division. In addition to the Sub Divisional Police Officers, the district SSP is also generally assisted by a Supdt. of Police (Hqrs) and a Supdt. of Police (Detective). In smaller districts, there may be only a Dy.Suptd. of Police (Hqrs) or Dy.Suptd. of Police (Detective). In bigger cities there are even posts of Supdt. of Police (City) who supervises one or more sub divisions. There may also be an SP (Ops) and/or SP Traffic in these bigger cities.

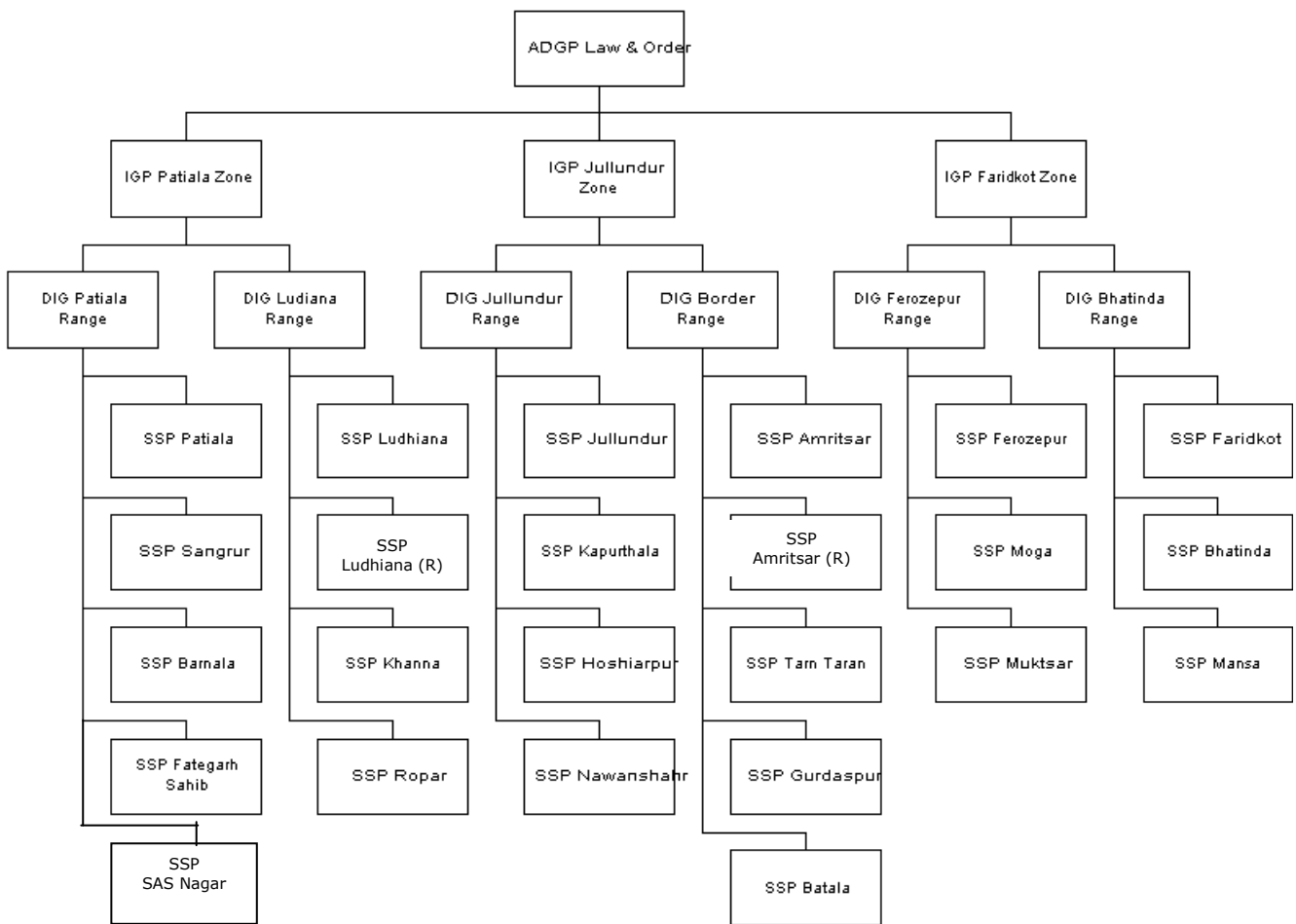

The organizational set up of each of the 24 districts is given below in the alphabetical order of districts. Structure is shown up to police station level. The police posts have not been shown.

District Police Amritsar (City)

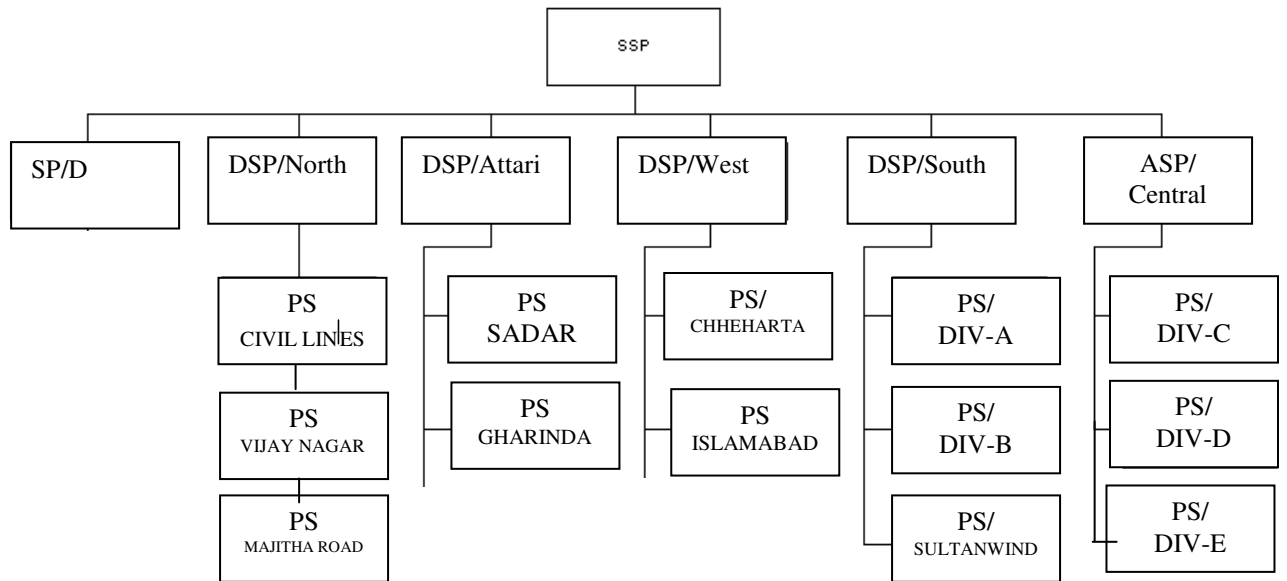

District Police Amritsar (Rural)

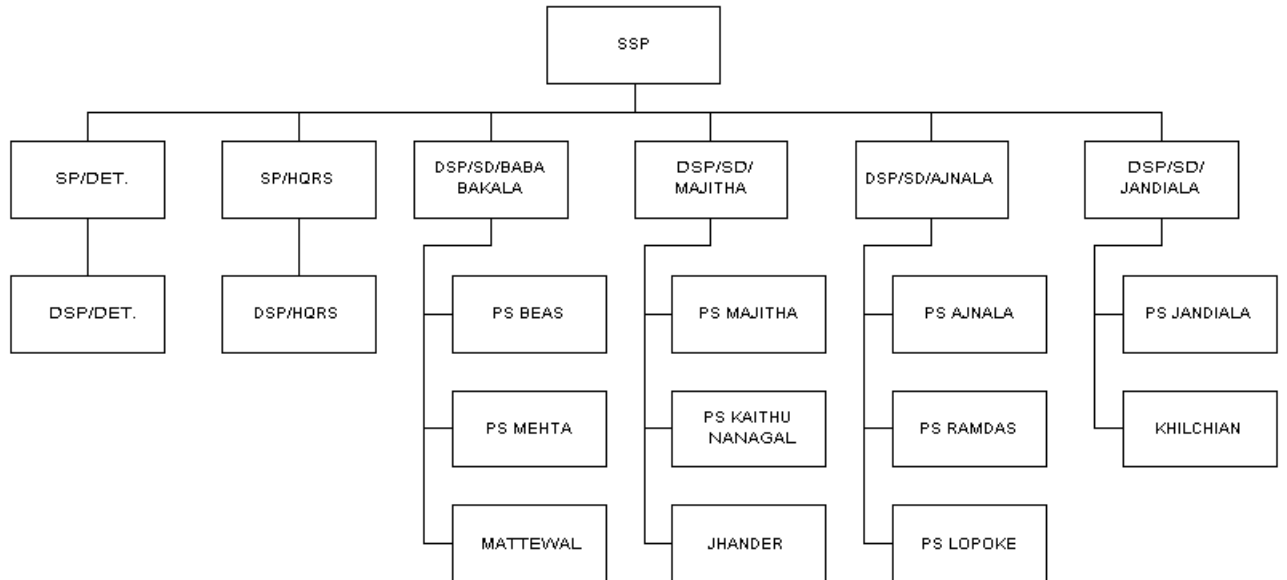

DISTRICT POLICE BATALA

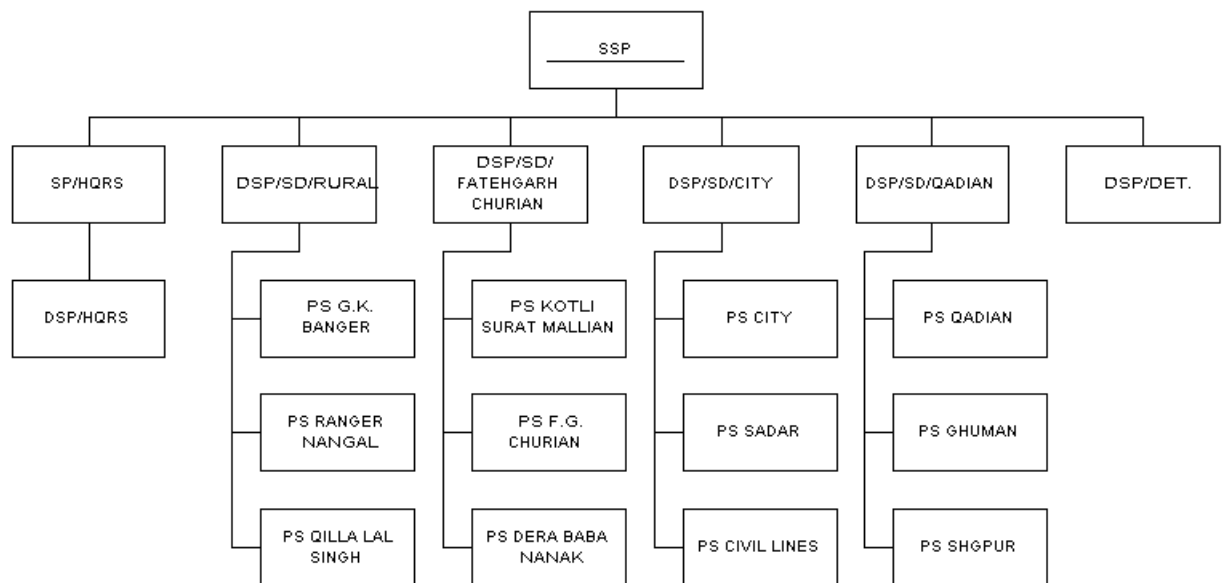

DISTRICT POLICE BARNALA

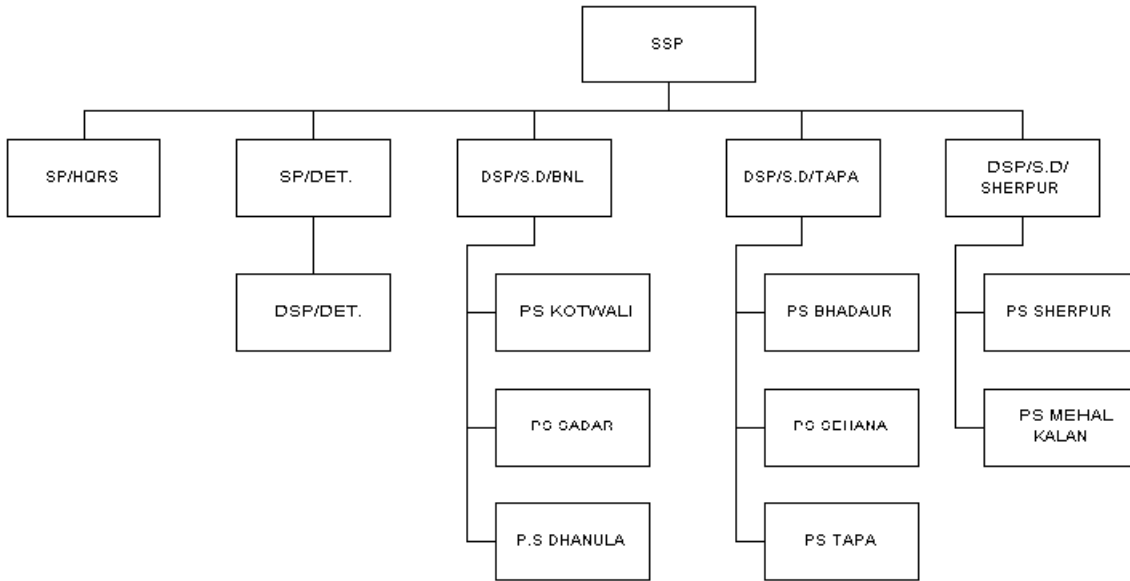

DISTRICT POLICE BATHINDA

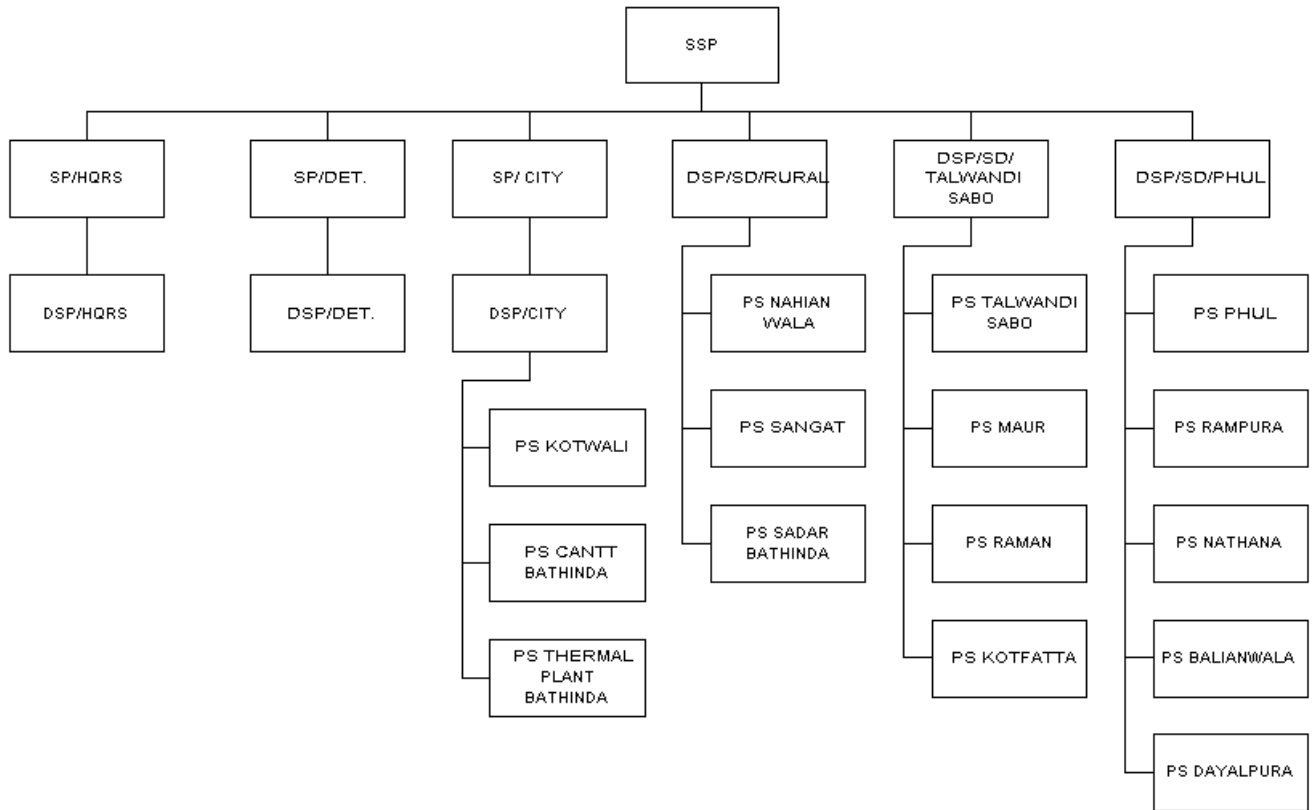

DISTRICT POLICE FARIDKOT

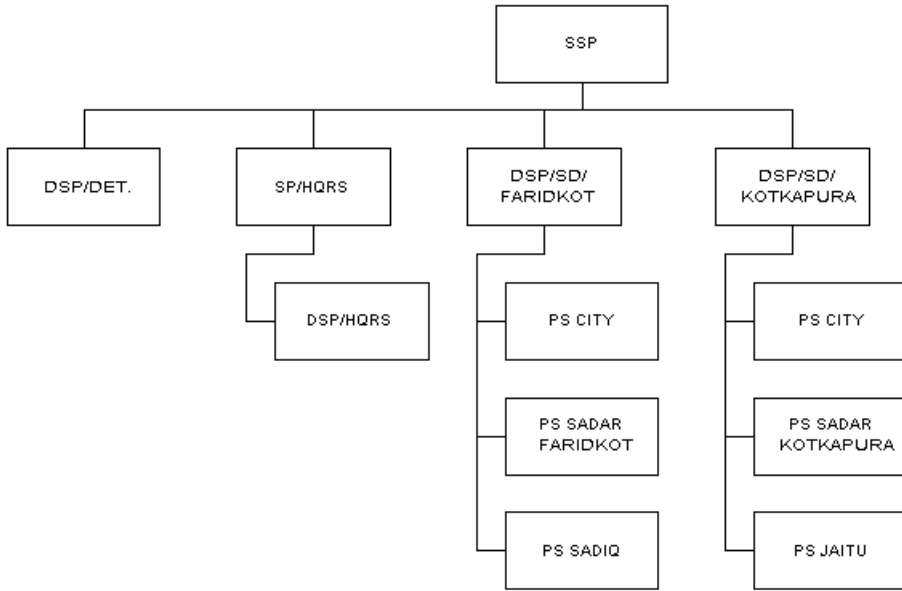

DISTRICT POLICE FATEHGARH SAHIB

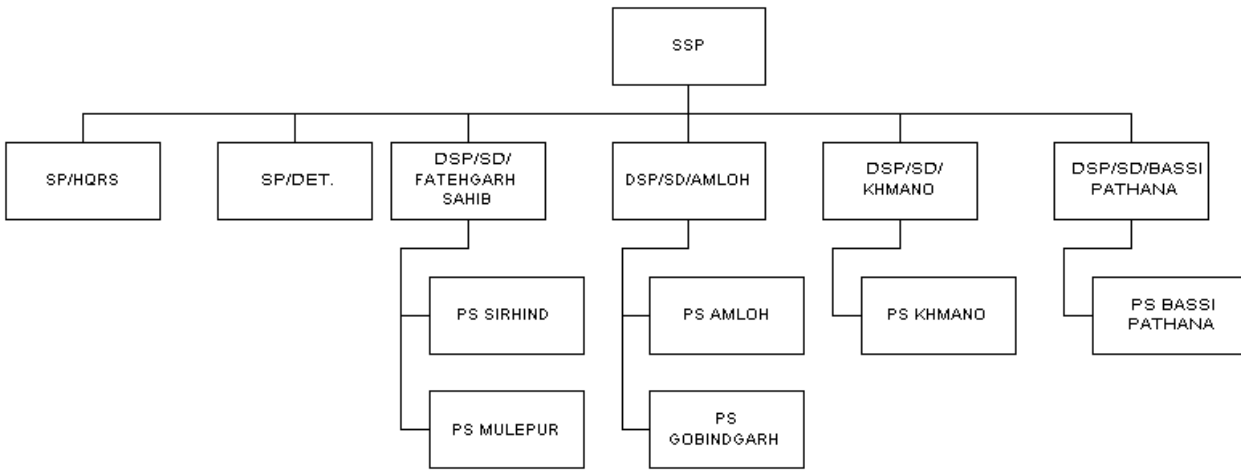

DISTRICT POLICE FEROZEPUR

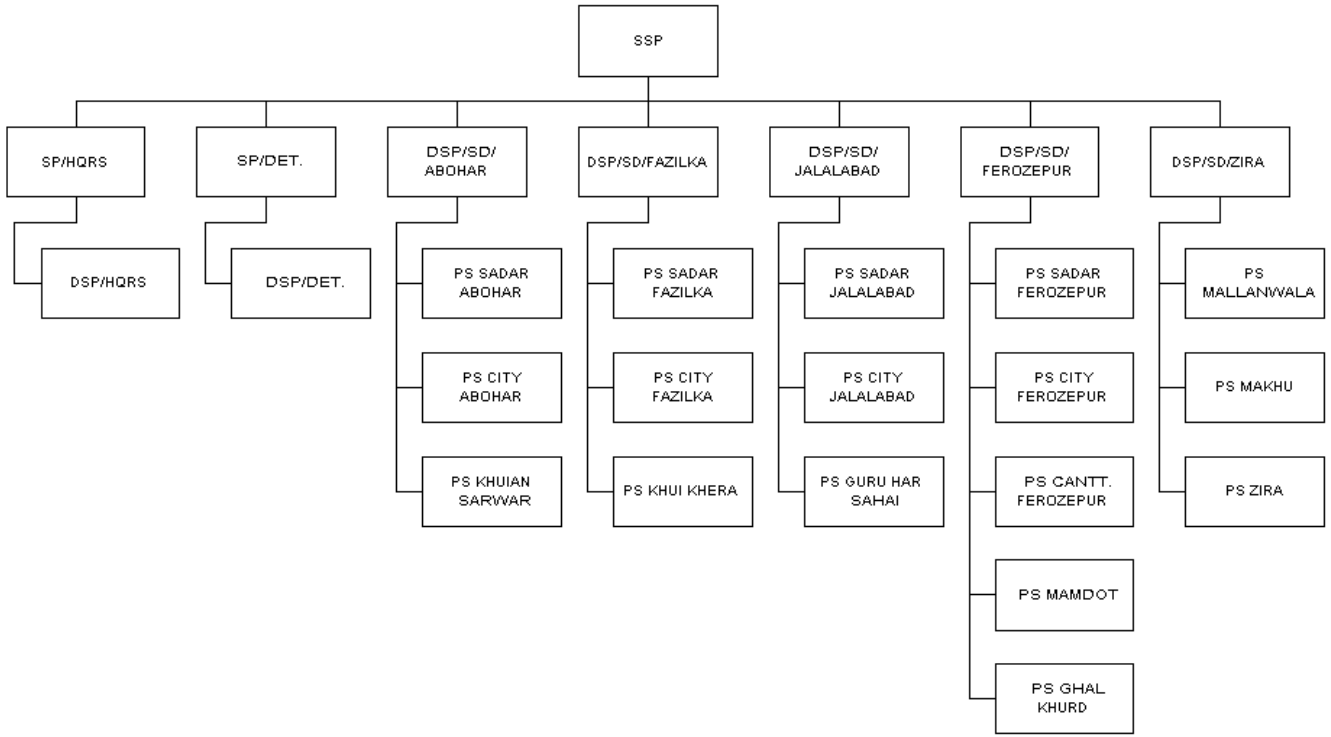

DISTRICT POLICE GURDASPUR

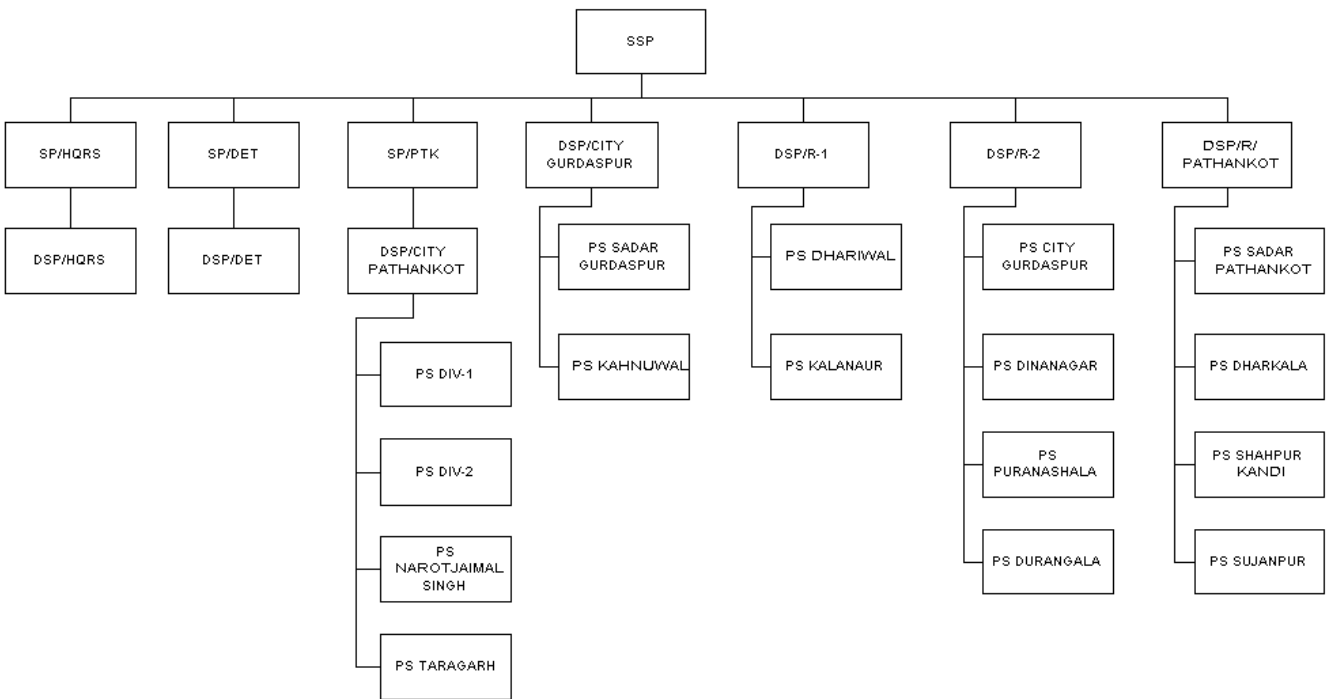

DISTRICT POLICE HOSHIARPUR

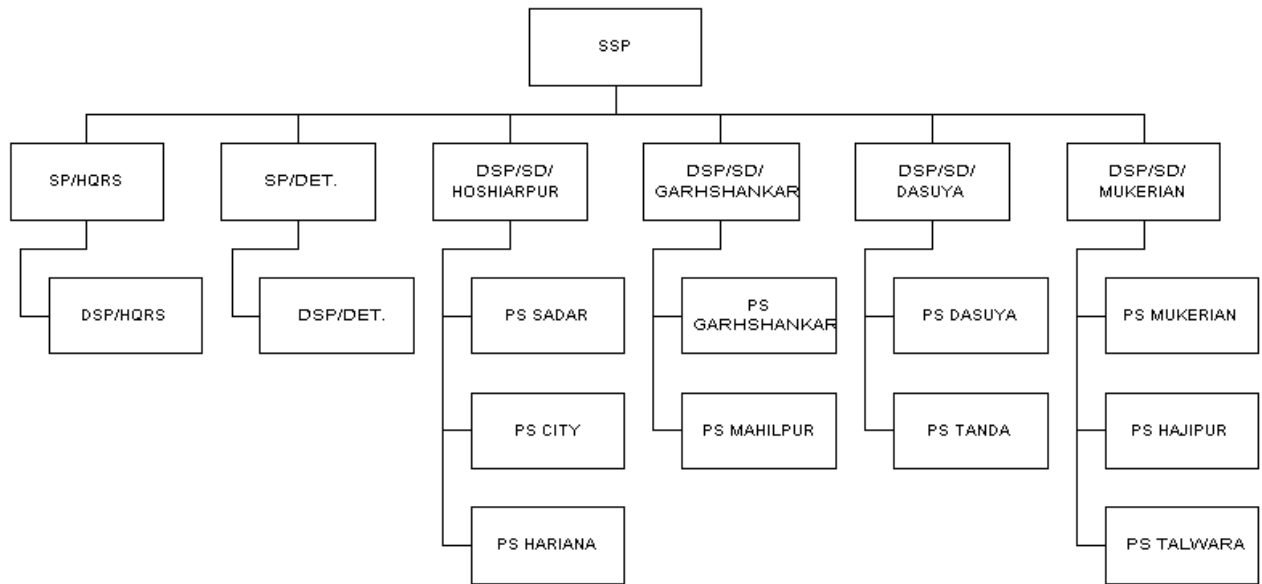

DISTRICT POLICE JALANDHAR

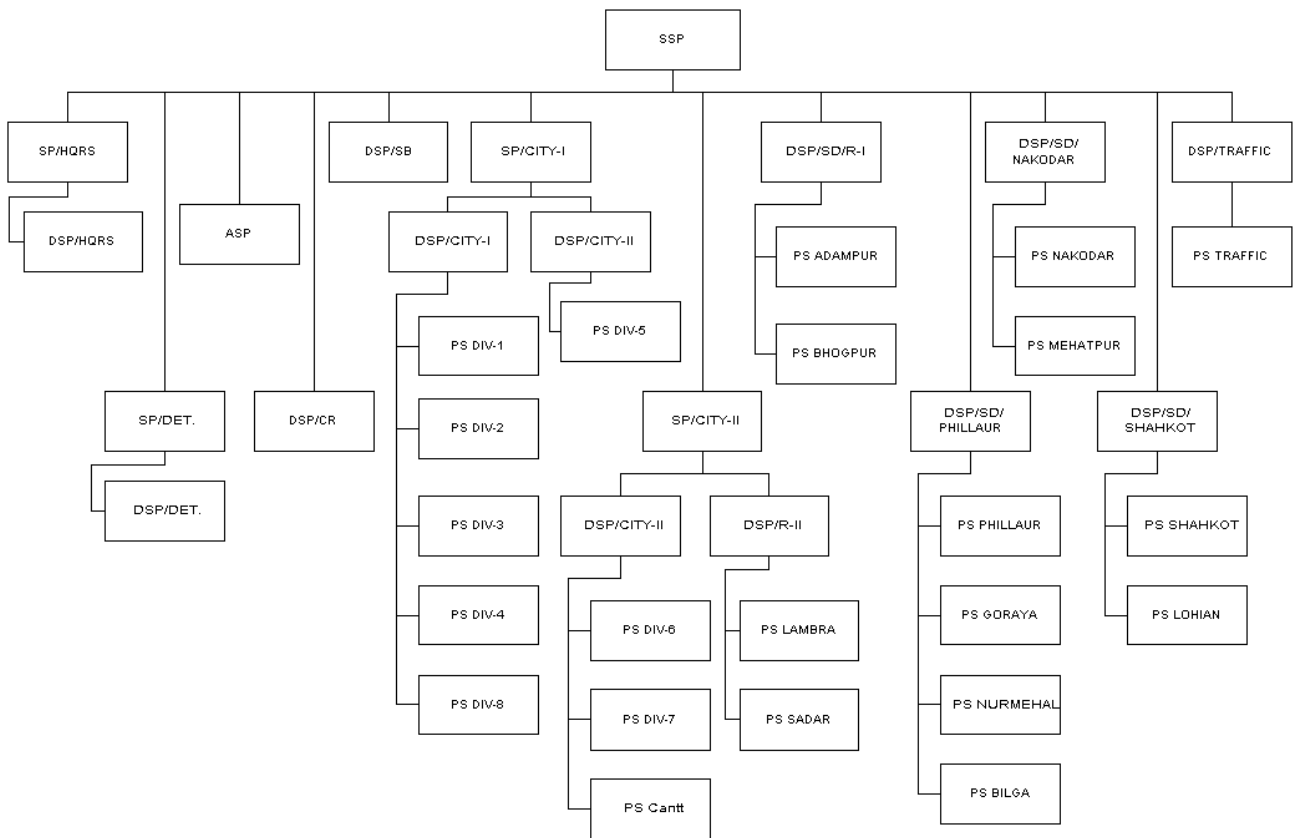

DISTRICT POLICE KAPURTHALA

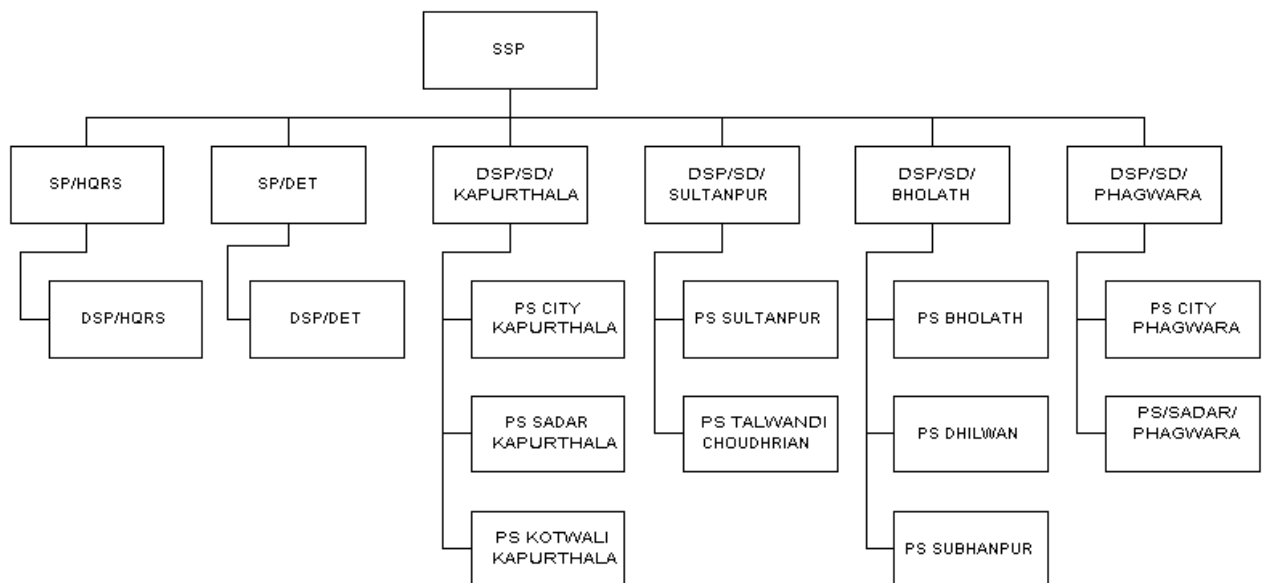

DISTRICT POLICE KHANNA

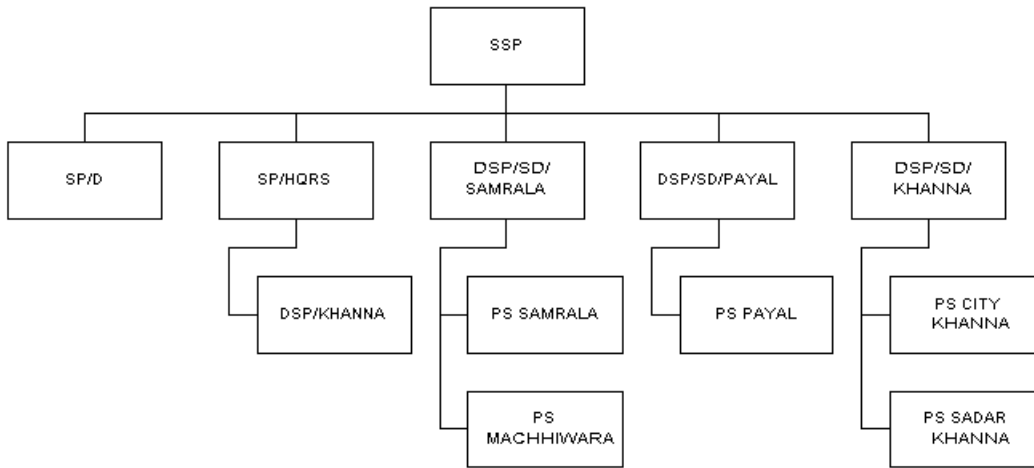

DISTRICT POLICE LUDHIANA (City)

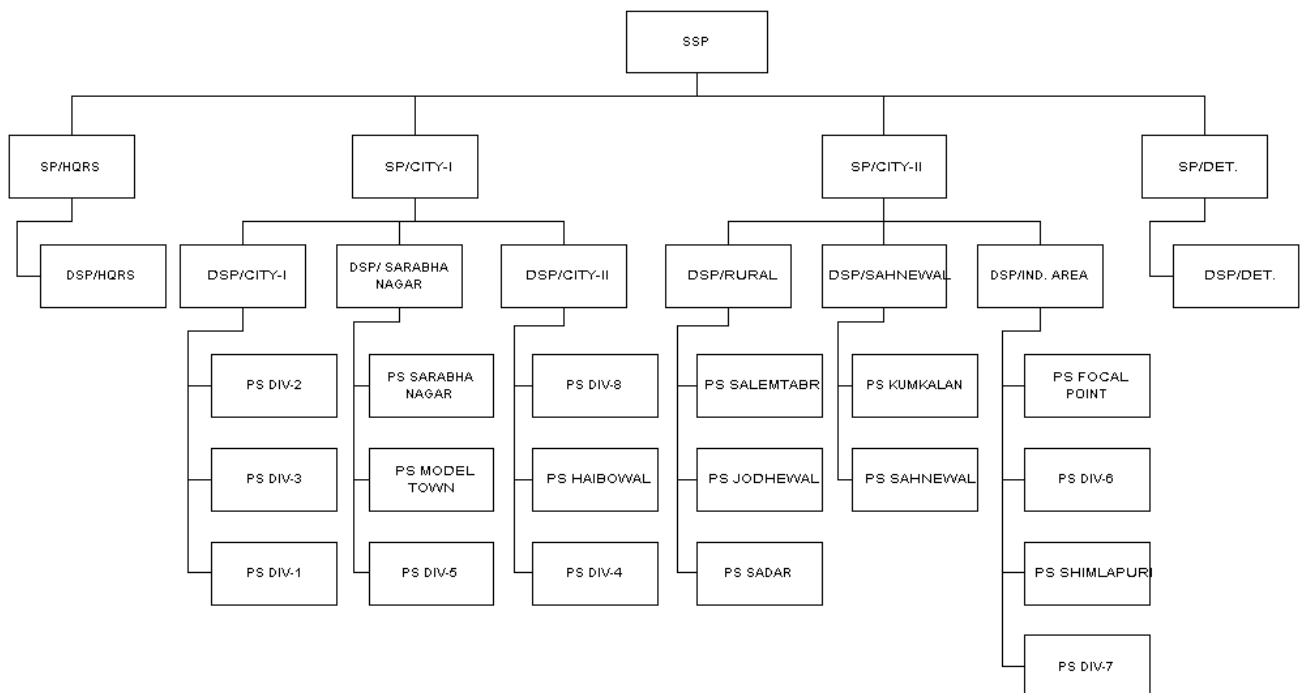

DISTRICT POLICE LUDHIAN (RURAL)

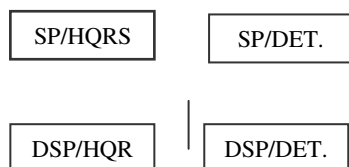

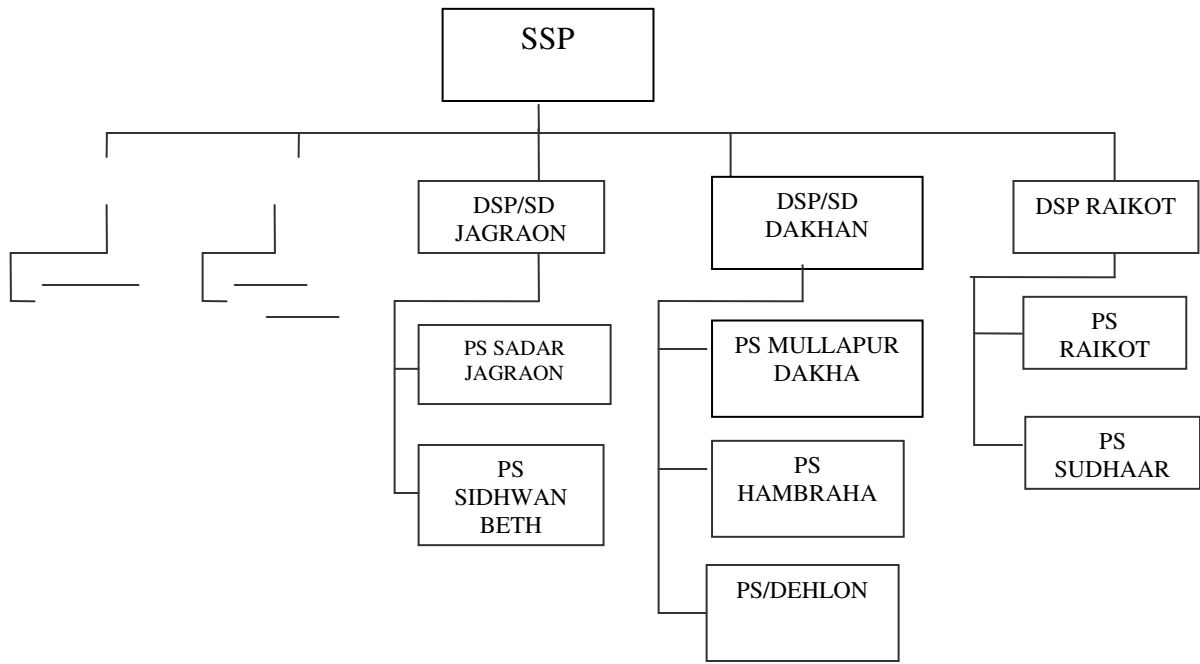

DISTRICT POLICE MANSA

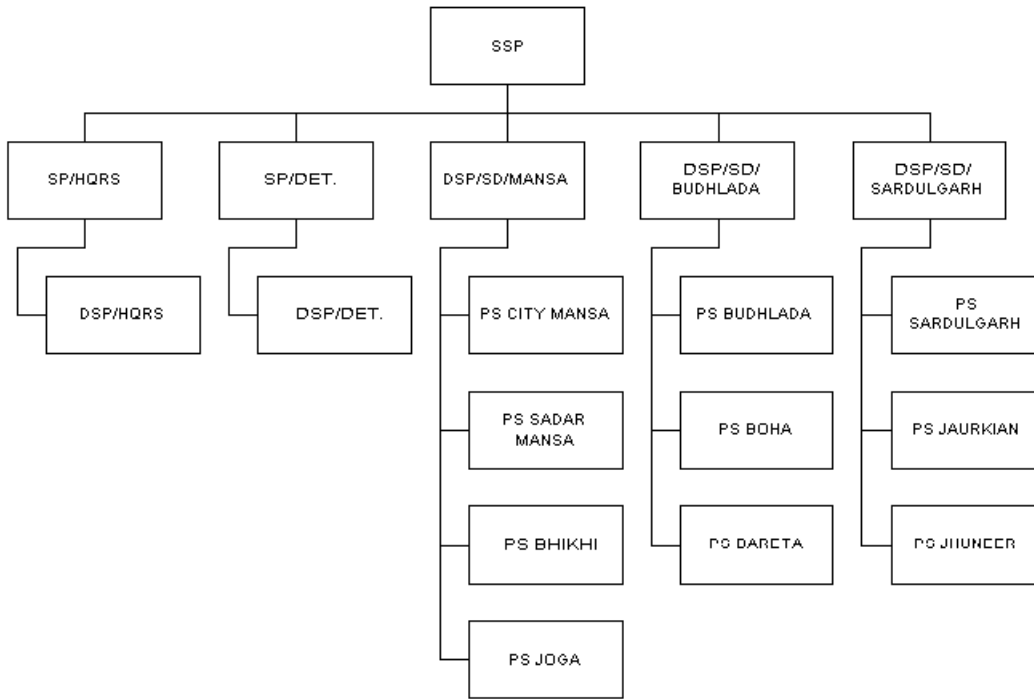

DISTRICT POLICE MOGA

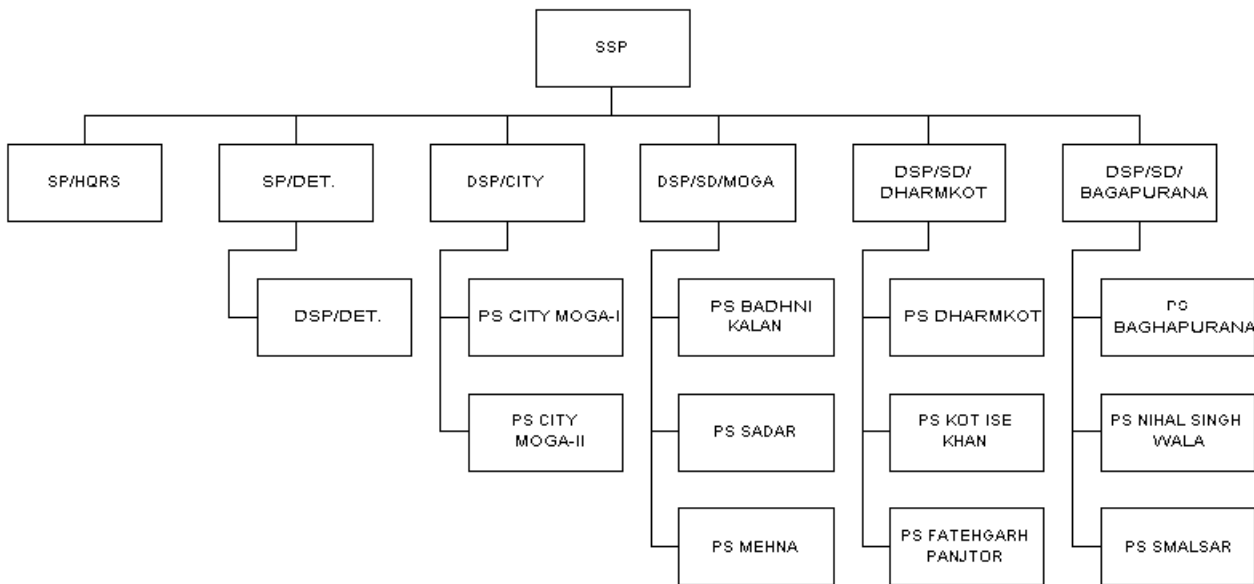

DISTRICT POLICE MUKTSAR

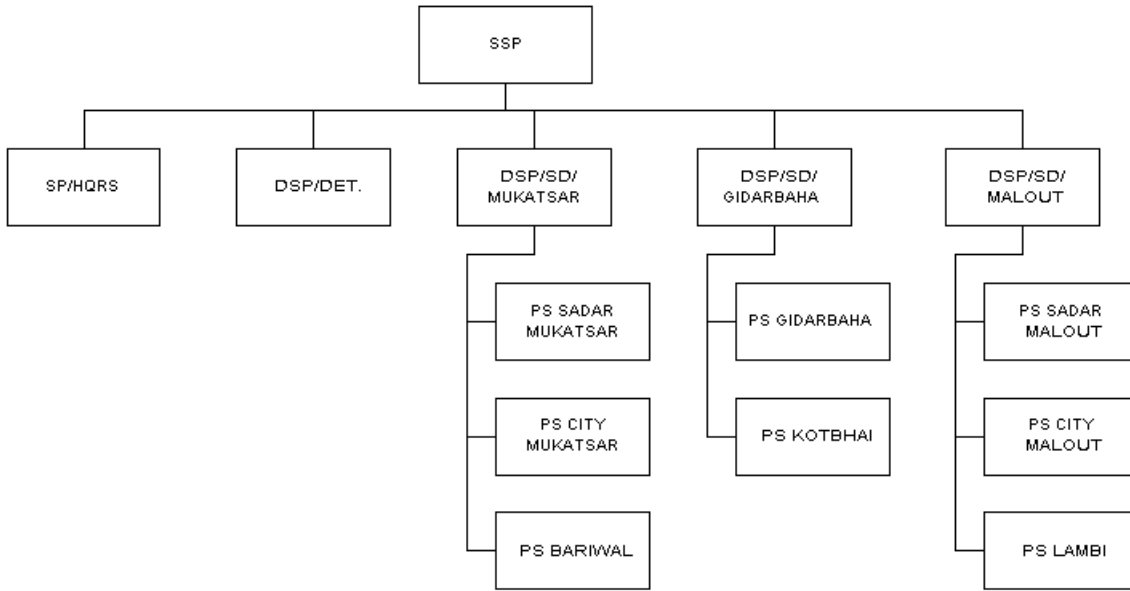

DISTRICT POLICE PATIALA

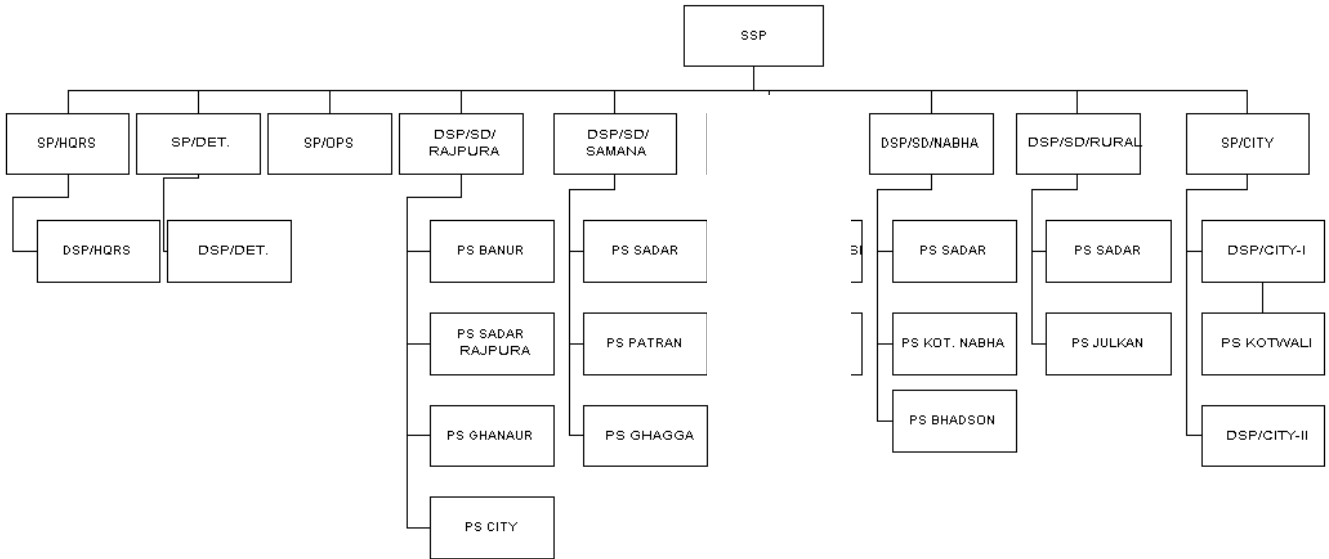

DISTRICT POLICE ROPAR

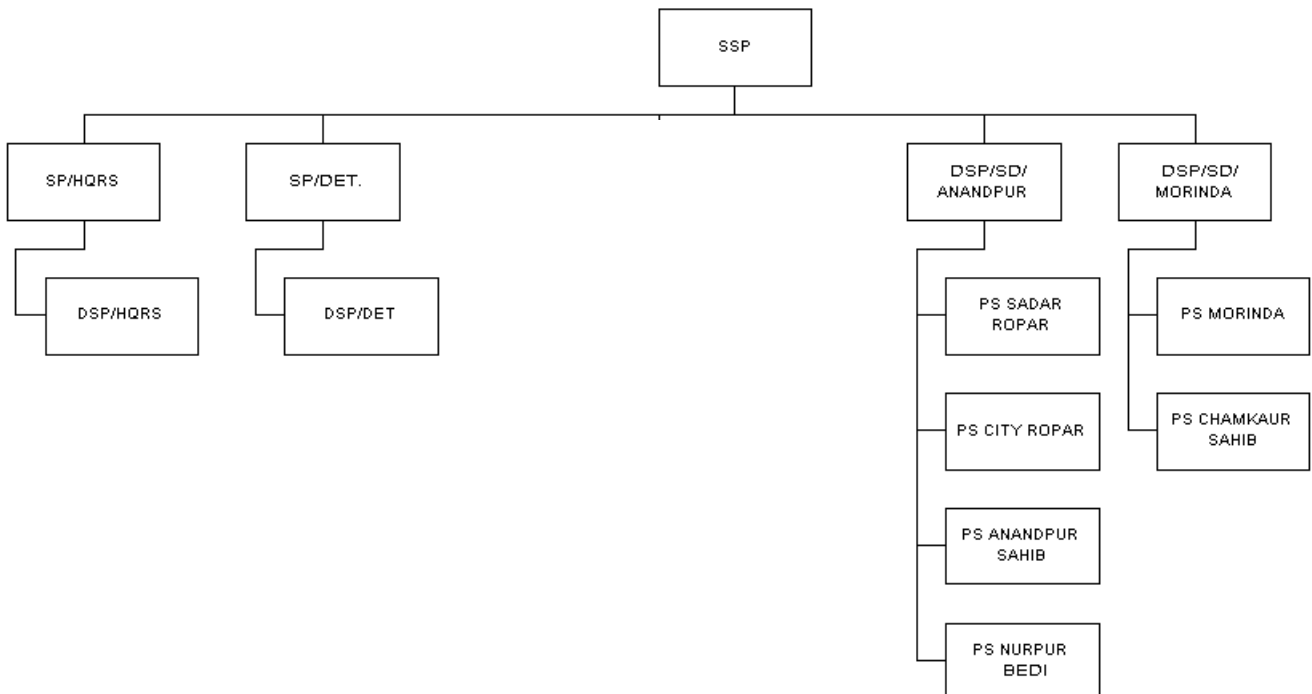

District Police Shaheed Bhagat Singh Nagar

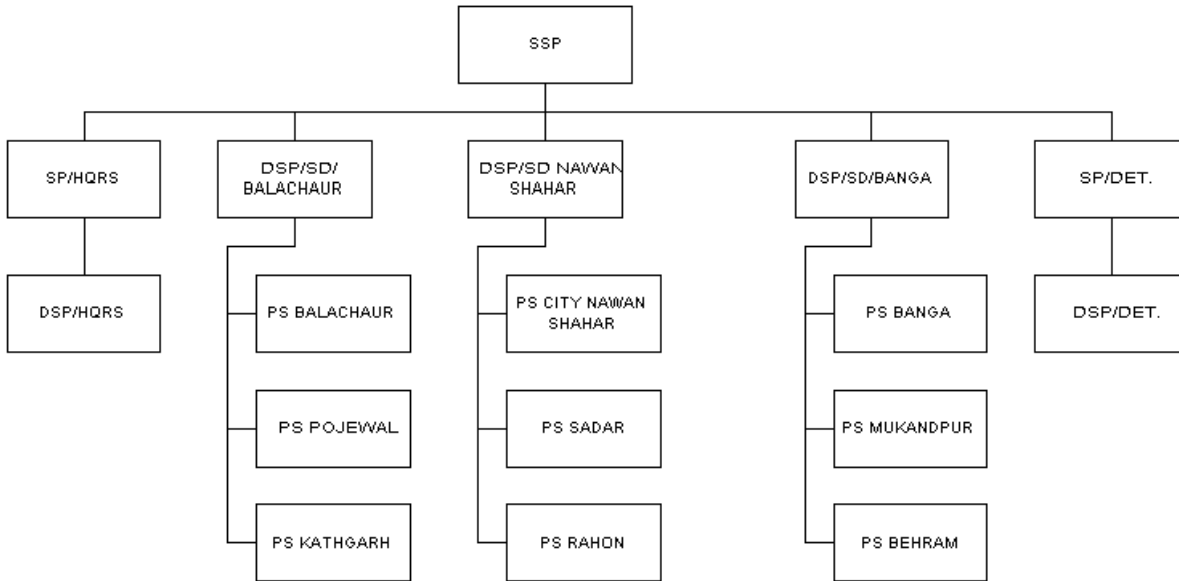

DISTRICT POLICE SANGRUR

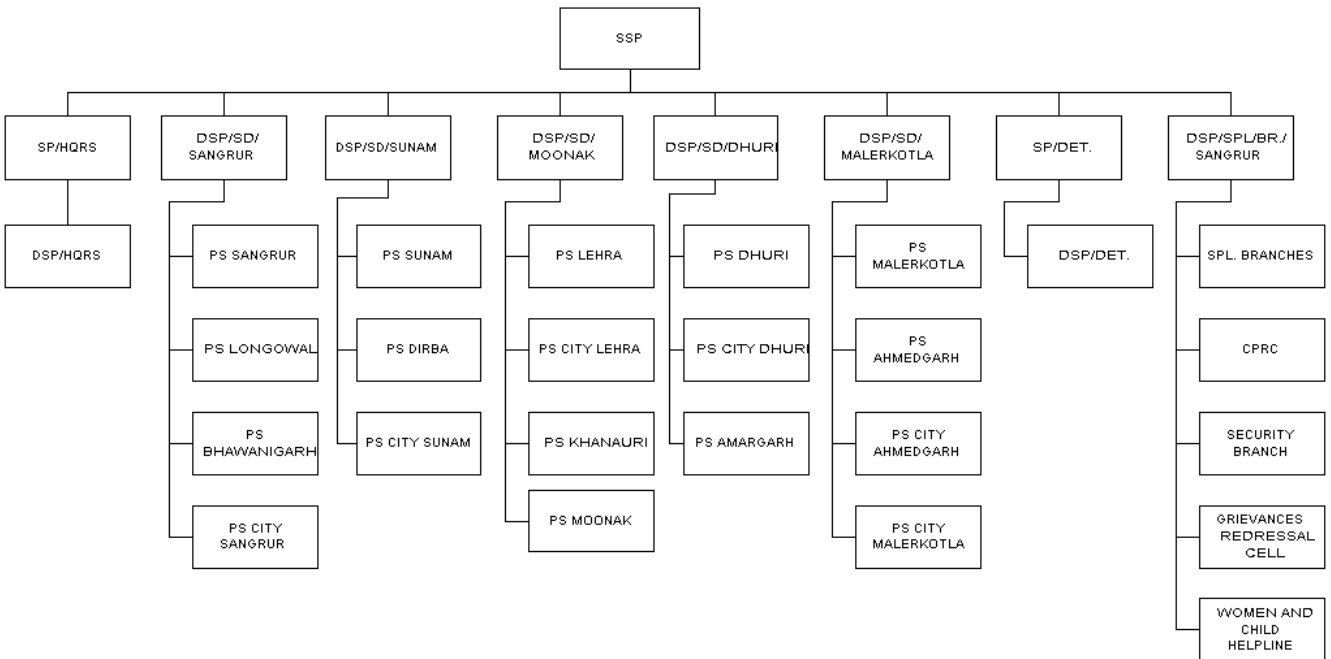

DISTRICT POLICE S.A.S. NAGAR

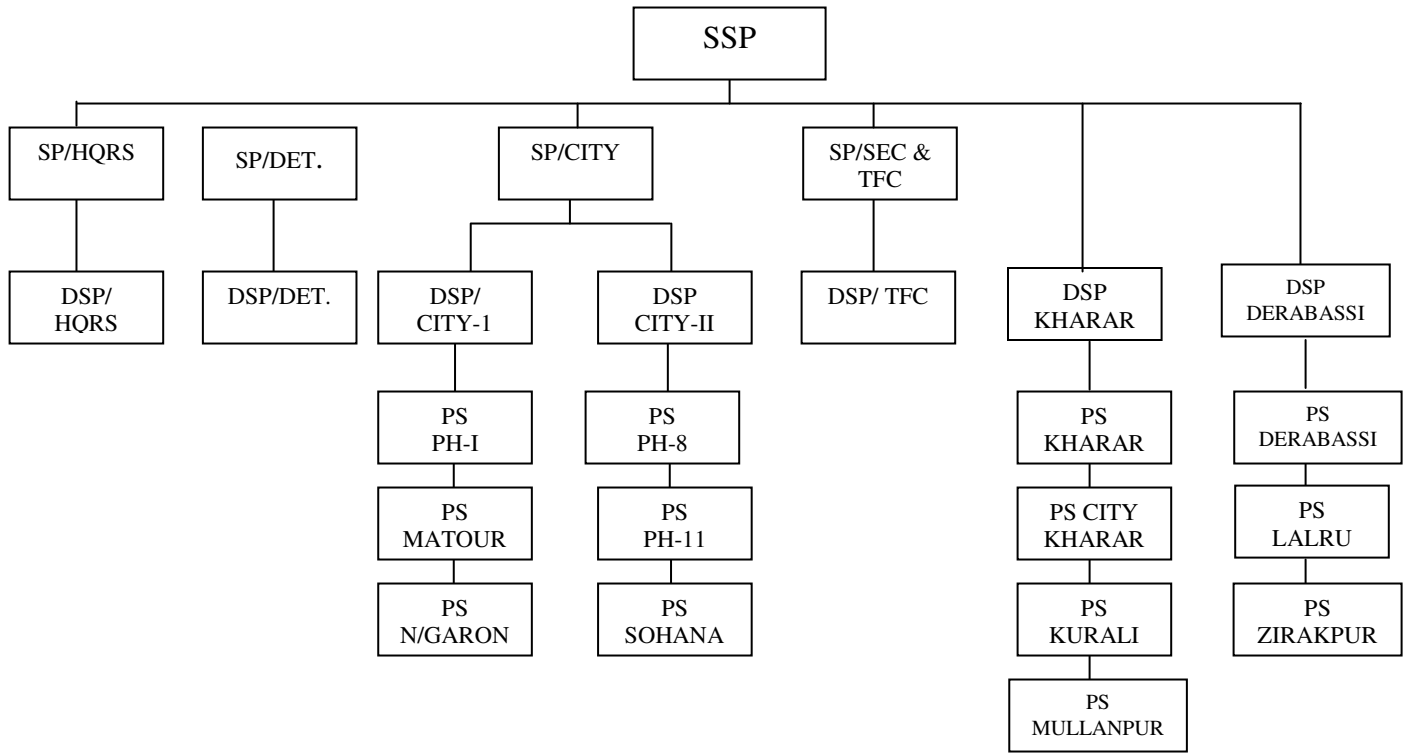

DISTRICT POLICE TRAN TARAN

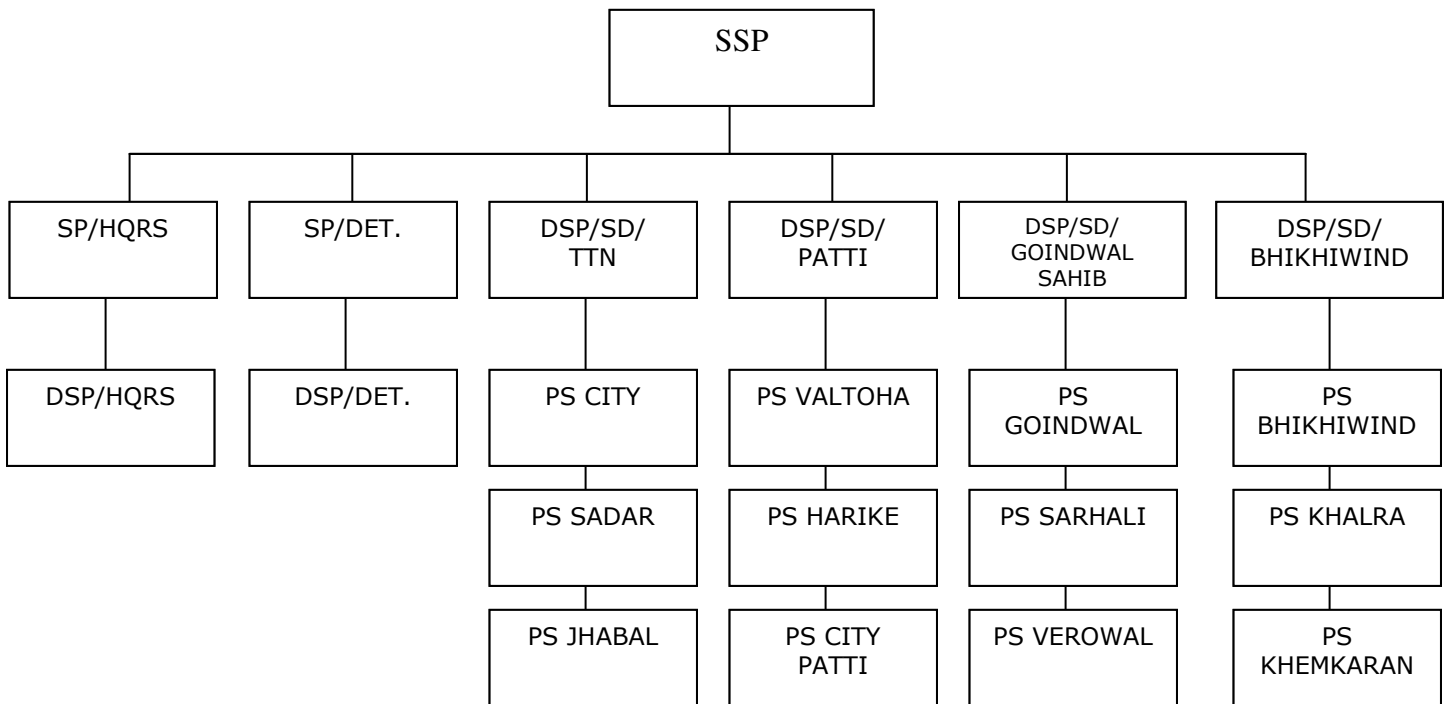

B. ADMINISTRATION WING

The Administration Wing is headed by ADGP Admn. It is also popularly known as Central Police Office (CPO). The main functions of this wing are the management of resources of the department including human resources and other material resources such as vehicles, buildings etc. It also deals with policy planning and implementation. It is organized as below:-

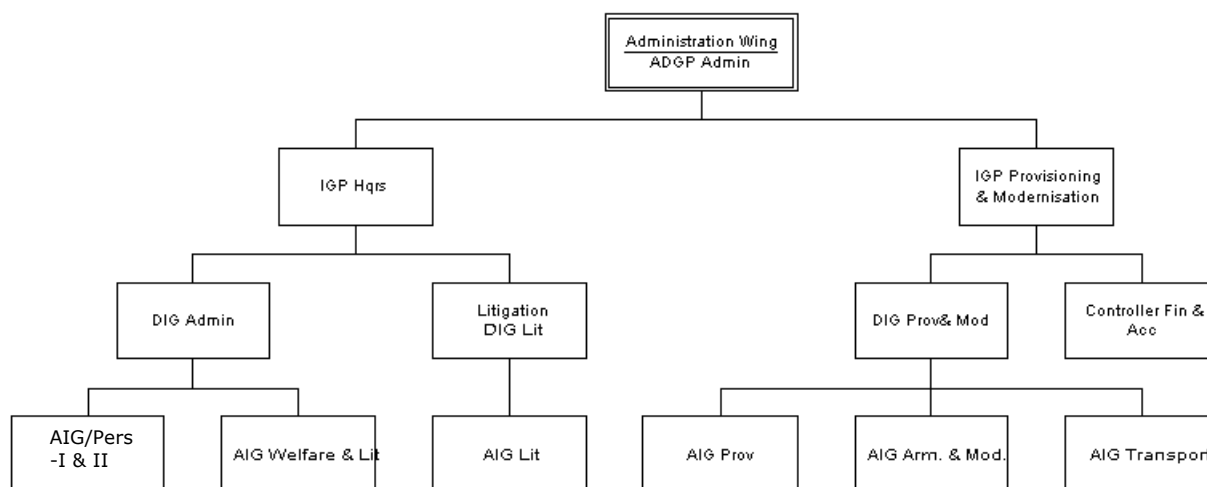

All issues pertaining to human resources including service matters of the officers/officials of the department are handled by the Hqs division which is headed by IGP (Headquarters) who is assisted by two DIsG and three AIsG. The main functions of the Headquarters division are as below:-

1. **Service matters pertaining to Officials from the rank of constable up to Inspector**
 - a. Recruitments/ Recruitment and allocation in the ranks of Inspector, ASI and Constable by:-
 - i) Direct recruitment;
 - ii) Under Priority List Instructions (PLI) i.e. compassionate appointments;
 - iii) Absorption of SPOs as constables;
 - iv) Absorption of officials from the rank of constable to Inspector from other police organizations.
 - b. Confirmations

Confirmation of directly recruited ASIs and Inspectors
 - c. Seniority;
 - i) Maintenance of seniority of Inspectors and publishing of their 'Gradation lists';
 - ii) Drawing up of list 'F' for promotion to rank of Inspector;
 - iii) Maintenance of Central seniority Roster for Head Constables, ASIs and SIs (excluding Armed police and C&T wing);
 - iv) Drawing up of promotion lists D-I & D-II for both men's and women's cadre for promotion to the rank of Asstt. Sub-Inspector;
 - v) Drawing up of promotion lists E-I & E-II for both men's and women's cadre for promotion to the rank of Sub-Inspector;
 - vi) Bringing constables on list C-II;

d. Promotions;

- i) Regular promotions to the ranks of ASI, SI and Inspector;
- ii) Out of turn promotions in exceptional cases upto the rank of Inspector;

e. Promotional courses;

- i) Nomination of candidates for the Intermediate School course;
- ii) Nomination of candidates for the Upper School Course;

f. Transfers;

- i) Transfers of Inspectors;
- ii) Inter-district transfers of HCs and Cts on compassionate grounds;
- iii) Inter range transfers of Sub-Inspectors and ASIs ;Temporary attachments

g. Deputations

Deputations of all ranks upto Inspector to Municipal Corporations, Excise & Taxation Deptt., PSEB, Vigilance Bureau, IB, CBI etc.

h. Matters of SPOs;

Deployment of SPOs in bodies other than police

i. Appeals concerning representations against;

- i) Major punishments awarded under PPR;
- ii) Adverse remarks in ACRs from HC to Insp.;
- iii) Service matters like seniority, nomination to promotional course etc.;
- iv) Other miscellaneous issues

j. Manpower planning and policy;

- i) Creation of new posts;
- ii) Amendment in rules;
- iii) Creation/ continuance of temporary posts;
- iv) Continuance of posts of SPOs each year

k. Regularization of contingent paid staff.

2. **Service matters concerning PPS Cadre:**

The cadre controlling authority of Punjab Police Service Officers is the State Govt. However, the Hqrs division maintains necessary record of all officers borne on this service and also deals with proposals concerning:-

- a. Calculation and projection of demand for officers

- b. Drawing up of 'G' list for promotion to the rank of DSP and promotion thereof.
- c. Confirmation of PPS officers
- d. Transfers and postings. Orders of DSPs are issued by DGP while those of Offg. SPs are done by the Govt.
- e. Deputation to other departments such as Vigilance, PSEB, Municipal Corporations, Excise & Taxation etc.
- f. Deputations of GOs (other than IPS officers) into the State Police.
- g. Preparation of gradation and distribution list.
- h. Maintenance of seniority.
- i. Promotion into Indian Police Service.
- j. Complaints against PPS officers
- k. Initiation of disciplinary actions and maintenance of record of DEs/ VEs/ CrI. Cases.
- l. Maintenance of ACRs
- m. Handling of appeals against seniority related matters
- n. Handling of appeals against adverse remarks in ACR.
- o. Sanctions/ promotions/ intimations under Conduct Rules i.e. concerning movable/immovable properties/ gifts/ loans etc.
- p. Property returns.
- q. Earned leave record.
- r. Leave encashment
- s. Continuance in service beyond 55 years of age.
- t. Voluntary/ compulsory retirement
- u. Superannuations upon 58 years of age.

3. State cadre of IPS Officers:

The cadre controlling authority of Indian Police Service Officers borne on the State of Punjab is the Ministry of Home Affairs, Govt of India. However, the Hqrs division maintains necessary record of all officers and deals with proposals regarding the following:-

- a. Human resource planning and projection of demand
- b. Preparation of select list for induction of State Police Service officers into IPS.
- c. Confirmation
- d. Transfers and postings

- e. Deputation to Govt of India/ other units and from others States/ Organizations
 - f. Promotions to the rank of SPs/DIsG/IsGP/ADsGP/DGP
 - g. Grant of Selection Grade.
 - h. Preparation of Civil List.
 - i. Suggestions regarding Amendments to the All India Service Rules.
 - j. Preparation of periodic returns.
 - k. Review of the IPS cadre
 - l. Review on completion of 30 years of service/ 50 years of age.
 - m. Voluntary/ compulsory retirement
 - n. Sanction/ permissions/ intimations under the All India Service Conduct Rules governing transactions of movable/ immovable properties/gifts etc
 - o. Maintenance of ACR files
 - p. Complaints against officers and departmental action.
 - q. Representations concerning service matters
 - r. Representations against adverse remarks in ACRs
 - s. Sanctioning of leave and its record
 - t. Grant of NOC to visit foreign countries.
 - u. Leave encashment.
4. **Establishment matters pertaining to Cadre of Ministerial Staff:**
- a. Direct recruitment in the rank of Peon, Clerk/ Steno-typist.
 - b. Transfers/ postings and deputations
 - c. Confirmations
 - d. Seniority list of all ranks
 - e. Promotions :-
 - i. Supdts Gr.I to Estt. Officers
 - ii. PA to Pvt Secys
 - iii. Sr.Scale Stenographers to PAs,
 - iv. Clerks/ Jr.Asstts/ Stenos to Sr Asstts.
 - v. Sr.Asstts to Supdt.Gr-II,
 - vi. Supdt. Gr-II to Supdts Gr-I,
 - vii. Jr.Scale Stenographers to Sr.Scale Stenographers
 - viii. Steno typists to Jr.Scale stenographers,
 - ix. Class-IV to Clerks
 - x. Clerks to Steno typists,
 - xi. Daftries to Restorers,
 - xii. Peons to Daftries/ Record-lifter/Mukh sewadars.

xiii. Placement of clerks as Jr.Asstt.

- f. Leave and leave encashment
 - g. Assured career progression scheme
 - h. Maintenance of ACRs
 - i. Representations on matters of seniority/ pay fixation etc.
 - j. Representations against adverse remarks in ACR
 - k. NOC for transactions relating to movable/immovable property and for issuance of passport.
 - l. Continuance in service beyond 55 years.
 - m. Special increments as per Govt instructions.
 - n. Complaints
 - o. Departmental action
 - p. Voluntary retirements/ superannuation.
 - q. Amendments of Punjab Police Ministerial Staff service rules.
5. **Establishment matters relating to lecturers/ readers in PPA Phillaur.**
6. **Establishment matters relating to scientists/ officers working in Forensic Science Lab.**
7. **Rewards/Awards:-**
- a. Nomination for gallantry medal, meritorious/ Distinguished medal.
 - b. Appreciation letters to GOs
 - c. Honorarium for Ministerial Staff.
8. **Deployment of police:**
- a. Out of State deployment
 - b. Deployment of Armed Battalions and district police within the State for major events/ law and order situations.
 - c. Arrangements for visit of VVIPs i.e. President/ Prime Minister.
9. **Coordination**
- a. Issues concerning reforms in Police
 - b. Conferences of senior officers such as DGPs conference and CS/DGP's conferences.
10. **Misc:**
- a. Reply to Assembly/ Parliament questions
 - b. Posting of DDAs/ ADAs in districts/ units and doctors in police hospitals
 - c. Annual administrative reports.

The Inspector General of Police Provisioning is the over all in charge of the Provisioning Division. He is assisted by one Dy. Inspector General of Police, three Asstt. Inspectors General of Police and one Controller (Finance & Accounts). Provisioning Division makes budgetary provisions of expenditure under different heads for each unit of the department.

Provisioning wing of the police department is responsible for all types of central purchases and for procurement of various items such as cloth and readymade items for uniform, tents, machinery and equipment, vehicles, acquisition of land for the construction of police houses and other buildings, minor works, hiring of buildings, purchase/ maintenance and repair of vehicles for police department, purchase of POL etc, and procurement of arms and ammunitions for the force.

It also deals with the preparation of annual budget/ revised estimates, preparation of annual plan under the modernization of State police Forces and utilization of funds provided by the Govt of India, MHA/ State Govt. In addition, it handles fixation of pay of Gazetted officers (including IPS officers, Deputationists, State Police Officers and other Gazetted officers etc) and also maintains the service record of these officers. This wing also handles the GP Fund accounts of all Gazetted officers, Inspectors and Ministerial Staff.

C. ARMED BATTALIONS

This wing comprises of 8 PAP Battalions, 5 Commando Battalions, 6 India Reserve Battalions and 3 Training Centres (Recruits Training Centre, In-Service Training Centre & Commando Training School). All the Battalions of the Armed Police are headed by the Commandants and Training Centres are headed by an officer of the rank of Supdt of Police.

The Wing is headed by an Addl. Director General of Police. He is assisted by Inspector General of Police, PAP, Inspector General of Police, Commando, and Inspector General of Police, India Reserve Battalions. They in turn are further assisted by an officer of the rank of DIG in each of respective formations.

The organizational structure is depicted as below:-

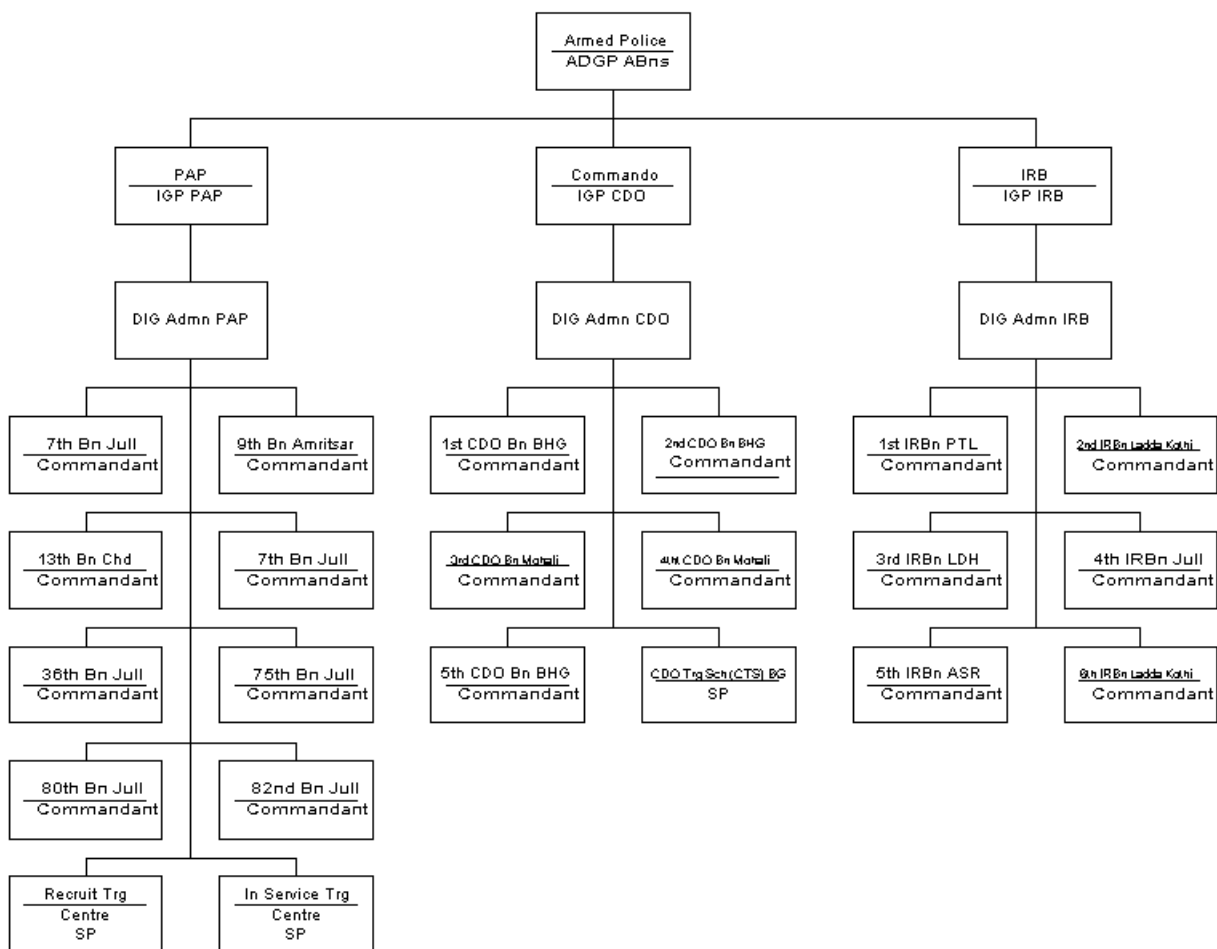

The important functions of the Armed Police are as follows:-

1. To guard vulnerable points and vital installations.
2. To assist the Distt. Police in maintenance of law and order.
3. To provide escorts, static guards and gunmen to threatened persons.
4. To perform Bank security duties.
5. To perform elections/ law and order duties in other States.
6. To provide force for duties such as celebration of festivals/ fairs and special operations against anti-social/ terrorist elements.
7. To perform out of State duty whenever ordered by the Govt.

D. CRIME WING

This wing is supervised by ADGP Crime who is assisted by other officers as shown below.

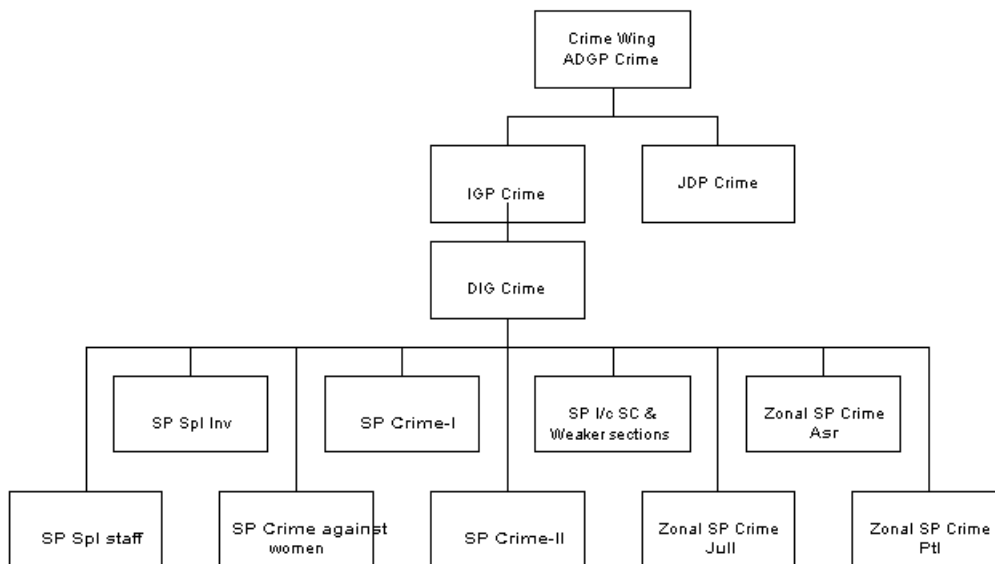

The main functions of this wing are:-

1. Collection, compilation and tabulation of crime data.
2. Investigation of important cases
3. Preparation of replies to questions of the parliament, State legislature and other Commissions etc.

Crime wing is organized in following branches each of which is supervised by an SP rank officer

1. Crime Branch
2. Special Staff
3. Women Cell
4. SC&ST Cell
5. Investigation Branch
6. M.O.B. Branch
7. ISR/CSR Cell

The functions and duties of the Branches are as under:

Crime Branch

1. Collection and tabulation of crime data and preparation of related reports.
2. Compilation of replies to Parliament/Assembly questions.
3. Litigation pertaining to criminal cases pending in Hon'ble Supreme Court /High Court cases and dealing with references received from Director Prosecution & Litigation, Punjab.
4. Meeting and conferences of National/ Inter-state level.
5. Fortnightly/Monthly Crime report.
6. All Establishment matters pertaining to Crime Wing.
7. Interpol references.
8. Extradition/R.C.N. cases.
9. Cases against Travel Agents.
10. Fake currency cases.
11. Accidental Deaths & Suicide cases.
12. Monitoring of ISR/CSR of Distts. & GRP.
13. Forensic Science Laboratory
14. Misc. Genl. Subjects.
15. Enquiries and Investigations of complaints/cases.

Investigation Branch.

1. Investigation/Inquiries cases and maintaining weekly record of all cases under investigation/enquiry.
2. Handling sanctions of prosecution.

SC&ST Cell.

1. Enquiry of complaints relating to SC&ST.
2. NHRC/PSHRC complaints.
3. Parliament/Assembly Questions.

Women Cell.

1. All matters pertaining to Crime against Women and Children.
2. Parliament/Assembly Questions.

Special Staff.

1. Enquiry of complaints and investigations.
2. Monitoring of reports from the concerned SSPs in field enquiries with regard to complaints received.
3. Estt./Functioning of OCIS (Organized Criminal Information System)

M.O.B.

1. Proclaimed Offenders/ Absconders.
2. Gangs.
3. Publication of CIA Gazette.

E. ECONOMIC OFFENCES WING

The Economic Offences wing was set up at Punjab Police Hqrs in 2004. It is headed by IGP EOW (Economic Offences Wing) who is assisted by DIG EOW. This wing reports to the DGP through ADGP Crime. It deals with offences involving fake currency, bank frauds, duping of depositors by finance companies, frauds, land grabs through use of faked documents, mushrooming of unauthorized colonies, money laundering and cyber crime etc. In addition, offences under special laws such as Copy Right Act are also handled by this wing. Each districts has an economic offences cell functioning under the SP/DSP (Detective). The functioning of these units and the investigation carried by them are also monitored by the E.O.Wing.

F. INTELLIGENCE WING

The State Intelligence Wing deals with the collection, collation, dissemination and record of matters pertaining to crime and of public importance. This includes information on criminal, anti-social activities and those events having a bearing on the maintenance of law and order in the State. One of its important functions is to keep the Govt informed on all matters of public importance. It also watches matters of interest from the security point of view. The State intelligence wing assists Central Intelligence Agencies in gathering information concerning national security. This wing is headed by an ADGP rank officer who is assisted by an IG, 2 DIGs and SPs as detailed in the chart below. ADGP Intelligence also supervises the security of Hon'ble C.M. for which purpose, he is assisted by DIG Security:-

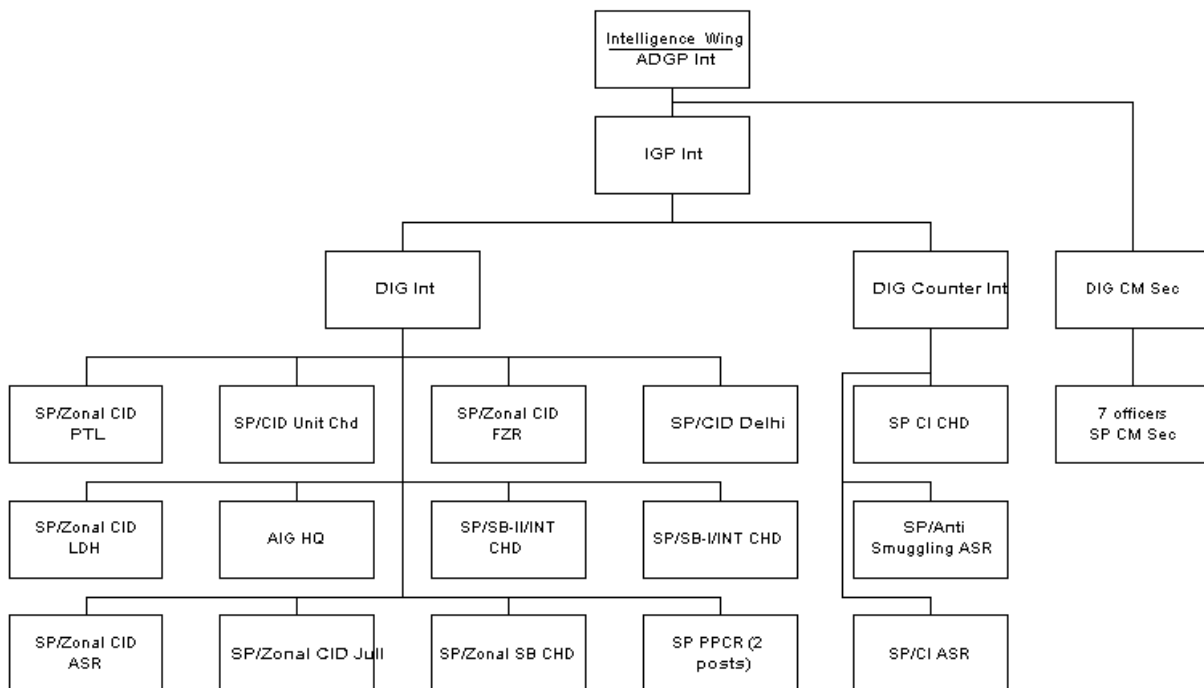

G. SECURITY WING

The Security Wing came into existence in 1993 after its bifurcation from the Intelligence Wing. Initially, the security of VIPs and vulnerable points (VPs) was being monitored by the Intelligence Wing. However, in 1993, this work was entrusted to the newly created security wing which is supervised by ADGP Security. He is assisted by DIG Security and 2 SPs.

H. INTERNAL VIGILANCE CELL (IVC)-CUM-HUMAN RIGHTS WING

This wing is the internal watchdog of Punjab Police. It looks into all complaints of corruption and allegations of human rights violations against Punjab Police officials. It is headed by ADGP IVC-cum-Human Rights. The Human Rights division is headed by an IG rank officer.

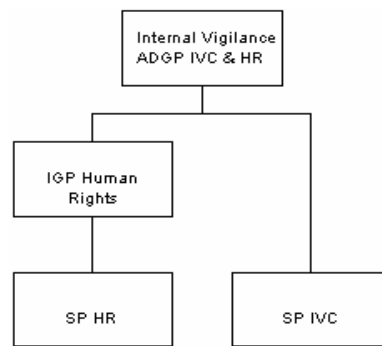

This division is the nodal agency for dealing with the complaints alleging to human rights violation received from National Human Rights Commission New Delhi, Punjab State Human Rights Commission, and other National commissions located at Delhi such as National Commission for Schedule Castes and Schedule Tribes etc. Complaints alleging human rights violation received directly in the division are also attended to.

I. TRAFFIC WING

The traffic wing functions at the Punjab Police Hqrs Chandigarh under the supervision of Inspector General of Police Traffic who is assisted by AIG Traffic. This wing deals with policies relating to traffic at the State level and coordinates with other departments / agencies of both State and Central Govt on these issues. It plans, purchases and distributes equipment for modernization of traffic police and monitors the traffic education activities of the districts. It also carries out training activities on its own.

It issues authorizations as per Govt notification for use of red lights/ beacons atop vehicles. It also engages in training activities. It collects and collates data regarding road accidents, traffic challans and information about help extended to roadside victims for transportation to medical centres. It monitors the functions of about 40 highway patrol vehicles in the State. Besides initiating proposals for better traffic management, it also carries out

research and runs refresher courses at Punjab Police Traffic Institute Phillaur. It also deals with all complaints against traffic personnel.

J. RULES WING

This wing is headed by an ADGP rank officer and is entrusted with the task of recommending amendments / fundamental changes in the various Rules/ Acts regulating the functioning of the State Police so as to improve and streamline the working of the police.

K. RAILWAY POLICE

The General Railway Police (GRP) is divided into 3 sub divisions viz; Patiala, Jalandhar and Ferozepur. These subdivisions are further divided into 11 Railway Police Stations viz; Patiala, Sangrur, Sirhind, Jalandhar, Ludhiana, Amritsar, Pathankot, Ferozepur, Faridkot, Bathinda and Abohar. The functions and duties of Govt Railway Police are as under :-

1. Maintenance of law and order on the railway system falling under its area of jurisdiction.
2. Prevention and detection of crime.
3. Ensuring the safety and security of the track and the travelers.

L. TRAINING WING & PUNJAB POLICE ACADEMY PHILLAUR

The basic function of Punjab Police Academy Phillaur is to provide integrated training for effective law enforcement through intensive professional training courses aimed at enhancing quality of command and professional knowledge for both recruits and in-service officers. It provides police training as per the Police Training College Manual as below:-

- a) Induction training of directly recruited officers in the superior and subordinate grades.
- b) Refresher and advanced training of experienced police officers.

- c) Specialized training in important aspects of police work.
- d) Training of higher grade officers in supervision, departmental enquiries and administration; and

The Punjab Police Academy Phillaur is headed by its Director who is also Addl. Director General of Police for the training wing of the entire police. For matters pertaining to PPA, he is assisted by one DIG-cum-Joint Director and 4 Dy.Directors as outlined in the organizational chart. For the training wing, he is assisted by IGP Training.

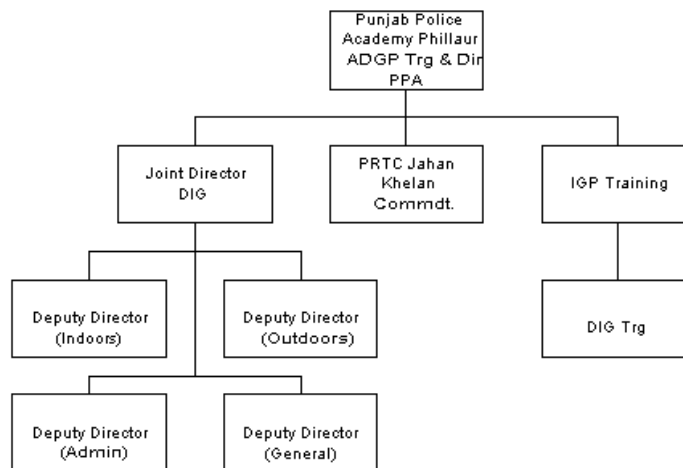

PPA designs, conducts and evaluates the following programs.

- Induction training for directly recruited Dy.S.Ps, Inspectors, ASIs and basic recruit training for female constables
- Lower, Intermediate and Upper school courses for promotion from the ranks of Constable to Head constables, Head constables to ASIs and ASIs to S.Is.
- Specialized in-service training for officers/ officials of different ranks.
- Training of trainer courses for trainers from PPA and other State Police Training Institutions.
- Vertical interaction and other training courses assigned and sponsored by Central Police Organizations like BPR&D
- Development of techniques and equipments for improving the efficiency of police force.

M. COMPUTERS & TELECOMMUNICATION WING

The Computer and Telecommunication Wing is headed by ADGP Computer & Telecommunication who is assisted by an IGP, a DIG and other officers as detailed in the chart below.

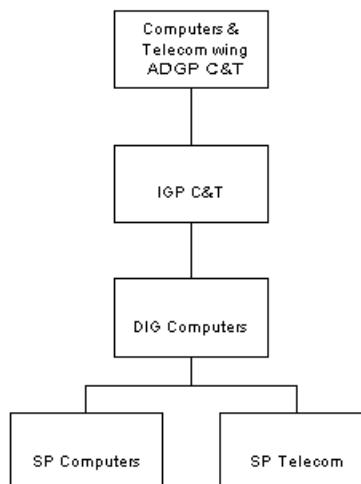

This wing provides round the clock communication linking the State Hqrs, the range Hqrs, Distt Hqrs and other police units in the field for the purpose of transmitting/ receiving important information and for clearance of messages relating to the maintenance of law and order and internal administration. For this purpose, the police department has its own dedicated radio communication and also utilizes hired circuits from the department of Telecommunications to support hot lines, fax, EPABX and computer communication. Long range HF, VHF, duplex and simplex modes of communication exist at all distt. Hqrs to communicate with their respective police stations and with vehicles of field officers. A communication network is also provided to the Armed Bns, Railway Police and to the Highway Patrolling Traffic Police. A satellite based police network (POLNET) system is also being installed at Police Hqrs and Distt Hqrs to provide end to end connectivity linking the National Capital, State Hqrs. and District Hqrs. all over India.

This wing is also responsible for the computerization of the department and for training of the officials. The computer wing is also the nodal agency for the maintenance of the data bases on different aspects of criminal information systems as below:-

1. Crime Criminal Information System (CCIS) : For maintenance of a data base of the State Crime Record Bureau and for integrating it with the National Crime Record Bureau. This database contains important information on criminals.

2. **TALASH** : A database for generating important information for the following categories:-
 - a) Wanted/ arrested persons
 - b) Lost/Kidnapped persons
 - c) Unidentified persons
 - d) Unidentified dead bodies
 - e) Deserters
3. Motor Vehicles Information Systems (MVIS) : To answer motor vehicle ownership queries
4. Licensed Fire Arms: To answer queries relating to the ownership of licensed fire arms.
5. Property coordination system : To maintain/ generate information on property having unique identification number. For instance, lost/ recovered motor vehicles, lost/ recovered fire arms etc.
6. Portrait building system: For generating rough sketches of criminals on the basis of inputs provided by witnesses.
7. Maintenance of an e-library
8. Computerized identity card system for the officials of the Punjab Police

This wing also deals with the schemes pertaining to the modernization of the State Police and for procurement of technical equipments.

Finger Print Bureau Phillaur is also under the administrative control of C&T Wing. The finger print bureau is a very important wing which provides information relating to criminals on the basis of finger prints. It maintains a large database and has a very sophisticated finger print analysis and criminal tracing system (FACTS) for this purpose.
